

Manchester Tool and Die

Model M94-H-6-G

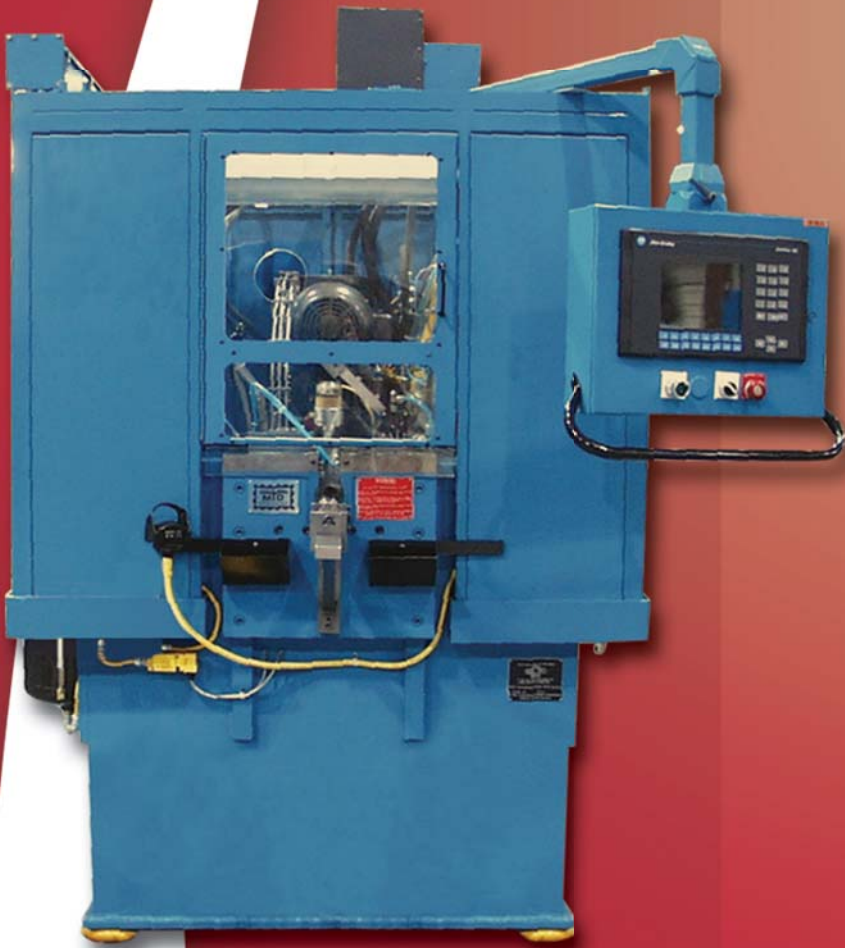

Model M94-H-6-G Tube End Forming System

The Manchester model M94-H-6-G is a hydraulically operated combination tube end forming and grooving machine. The machine includes a single stationary clamp for holding the tube as well as a transfer mounted Manchester six stroke end forming ram and a model 24008 tube grooving head. The forming ram and grooving head may be programmed to perform many combinations of end forming and grooving or cutting operations. Since the tube is only clamped once, excellent concentricity is maintained. Some of the many features and options available for this machine are listed on the other side.



www.manchestertoolanddie.com

Manchester Model M94-H-6-G Tube End Forming System

MTD SPECIFICATIONS

Standard Equipment

- Cycle Time: 8-20 seconds*
- Tube O.D. Capacity: .75"
- Maximum Jaw Opening: 1.75"
- Ram Cylinder: 3-1/4" bore x 8" stroke
- Ram Force: 8 tons (maximum)
- Main Drive Unit: 5 H.P. Haise Head
- Clamp Cylinder: 2-1/2" bore x 1-3/4" stroke
- Clamp Force: 17-1/2 tons (maximum)
- Hydraulic Unit: 20HP 32 GPM
- Working Pressure: 1200 PSI
- Maximum Pressure: 2000 PSI
- Air Required: 40 to 80 PSI & 3 CFM
- Electrical Required: Customer Specifications
- 12 Month Warranty on Machines
- Panelview Touch Screen

* Cycle time depends on the application and optional equipment.

Valuable Options

- Autoload & Unload Systems
- Custom Cycle Start Initiators
- Feeder Bowl Systems
- Part Present Sensor
- Light Curtains
- Custom Painting

CALL FOR AVAILABLE STOCK MACHINES

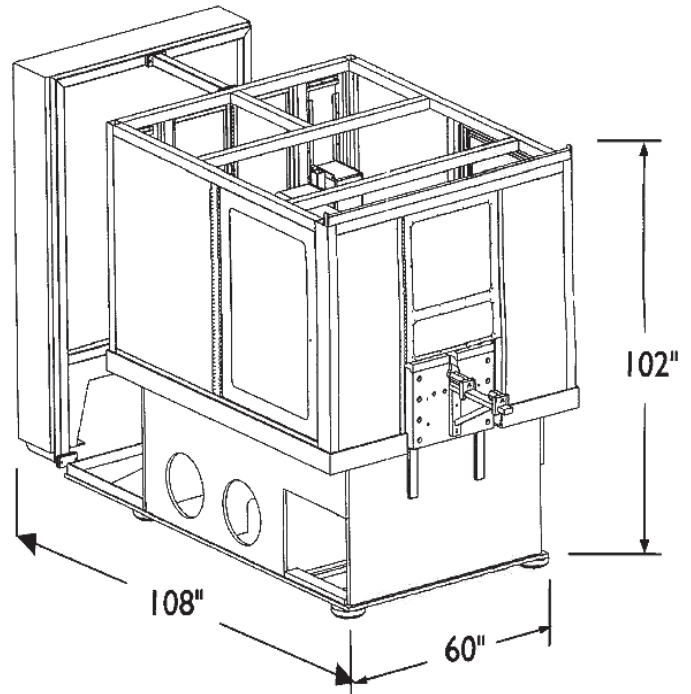

Machine weight without oil is approximately 12,000 lbs.

Advanced Features

- 1 to 6 Stroke and Double Index Capability
- Single Clamping for Multiple Operations
- Easy Access for Tooling Changeovers and Service
- Quickly Changeover to Roll or Cut Grooves
- Compact Footprint



Manchester Tool & Die, Inc. also works with the customer to create machines for unique applications.

Manchester Tool & Die, Inc.

P.O. Box 326 • 601 South Wabash Road • North Manchester, IN 46962
Phone: 260-982-8524 • Fax: 260-982-4575
Email: sales@manchestertoolanddie.com

Exceeding Expectations Since 1960 • www.manchestertoolanddie.com