

Manchester Tool and Die

Model 61000



Model 61000 Servo Crimp Machine

The Manchester model 61000 is an electrically controlled crimp machine designed to run either MTD's standard single-cavity or double cavity crimp dies. The crimp dies can produce either a two, four, six, or eight segment crimps. Machine is capable of running other brand of dies and can be used for other press applications.

The crimp machine tracks the force & position of each stroke and displays/logs the data, which can be downloaded by USB for review. Crimp speed is fully adjustable through the machine's HMI. Setup parameters to customer specifications are stored via recipes for ease of setup.



Contact MTD for more information:
Call 260-982-8524 or email at quotes@mtdbkb.com

www.mtdtube.com

Manchester Model 61000 Servo Crimp Machine

MTD SPECIFICATIONS

Standard Equipment

- Ram Cylinder: Servo Roller Screw Unit
- Rated Tonnage: 20 Tons Max
- Cycle Time: 3.5 seconds Min*
- Open Height: 14.0" (355mm)
- Throat Depth: 9.0" (229mm)
- Die Table Height: 40.5" (1029mm)
- Maximum Stroke: 4" (101mm)
- Adjustable Ram Stroke through HMI
- Dual Zero-Force Touch Buttons/Anti-Tie down
- RAL5015 Sky Blue Paint Color
- Easy Access for Die Changeover
- Electrical Required: Customer Specifications
- Recipe Storage through HMI
- 12 Month Warranty

*Cycle time is application dependent

Valuable Options

- Autoload & Unload Systems
- Safety Light Curtains with additional guarding
- Crimp Component Fixtures
- Custom Painting
- C.E. Certification

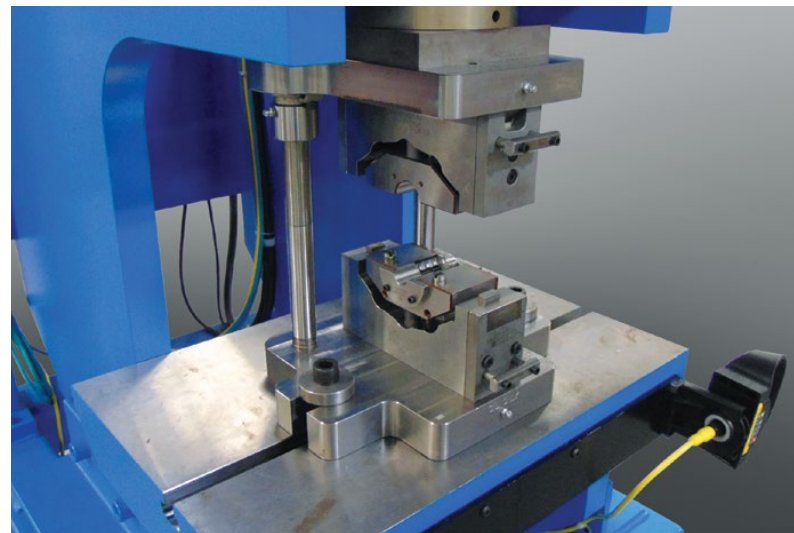
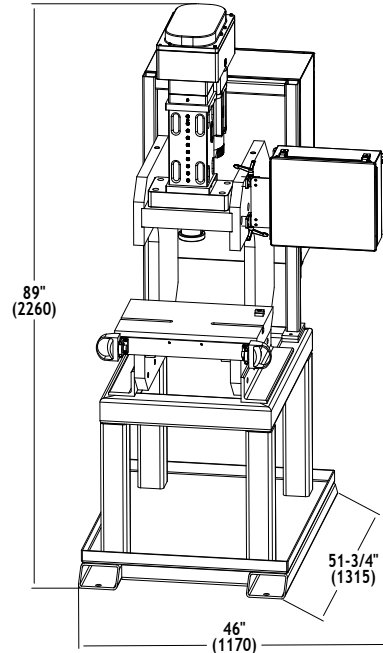

CALL FOR AVAILABLE STOCK MACHINES

Machine Weight is Approximately: 2,150 lbs.



Manchester Tool & Die, Inc. also works with the customer to create machines for unique applications.

Manchester Tool & Die, Inc.

P.O. Box 326 • 601 South Wabash Road • North Manchester, IN 46962
Phone: 260-982-8524 • Fax: 260-982-4575
Email: quotes@manchestertoolanddie.com

Exceeding Expectations Since 1960 • www.mtdtube.com